



USE AND CARE MANUAL

For Model CS892LP



Stop! Missing a part? DO NOT RETURN PRODUCT TO STORE

**The store where you made the purchase does not stock parts for this item. If you need parts, whether they are missing or damaged, please call Customer Service at 1-800-229-5647
Call us between 8:00 AM and 5:00 PM Eastern time, Monday through Friday
or email us at saleshelp@sureheat.com**

FOR YOUR SAFETY:

1. Read this Manual before attempting to assemble or operate your grill.
2. Follow safety instructions.
3. Check for leaks according to the directions in this Manual before operating your grill, even if purchasing an assembled grill.
4. Keep this Manual for future reference.
5. Contact **1-800-229-5647** should you need assembly assistance or have any questions.

THIS GRILL IS FOR OUTDOOR USE ONLY.

If stored indoors, then detach and leave propane cylinder outside.

General Safety Instructions

IMPORTANT SAFETY INFORMATION



- Read this manual carefully before using your grill to reduce the risk of fire, burn hazard or other injury.
- Extreme care should be used because of the high temperatures produced by this appliance. CHILDREN SHOULD NOT BE LEFT UNATTENDED IN AN AREA WHERE THE GRILL IS BEING OPERATED.
- This appliance must be kept clear from combustible materials, gasoline or other flammable vapors and liquids. Do not allow flammable materials to come in contact with grate, burner or hot surfaces.
- Use only outdoors and provide good ventilation to avoid carbon monoxide build-up which could result in injury or death.
- Do not repair or replace any part of this appliance unless it is specifically recommended in this manual. A qualified service technician should conduct all other service.
- Follow the installation and servicing instructions provided with this product. Have your grill installed by a qualified service technician.
- Locate the main gas supply valve so that you know how to shut the gas off to your grill.
- If you smell gas, make sure all gas connections are tight before operation. If you continue to smell gas call a qualified technician.
- When lighting a burner, always pay close attention to what you are doing and be certain you are pushing the igniter that lights the burner you intend on using.
- Always keep your face and body as far away from the grill as possible when lighting to reduce the risk of burn.
- Extinguish all flames and do not smoke while engaging gas and igniting the grill.
- A minimum distance of at least 24" must be maintained from any combustible material on both sides and the back of the grill. Do not place the grill under any overhead unprotected combustible construction.

RECOGNIZE SAFETY SYMBOLS, WORDS AND LABELS



WARNING

WARNING indicates a potentially hazardous situation which, if not avoided, could result in death or serious injury.



DANGER

NOTE indicates an important piece of information that needs to be observed to ensure the proper operation of your grill.

 **DANGER**

If you smell gas:

1. Shut off gas to the appliance.
2. Extinguish any open flame.
3. Open lid.
4. If odor continues, keep away from the appliance and immediately call your gas supplier or your fire department.

 **WARNING**

1. Do not store or use gasoline or other flammable liquids or vapors in the vicinity of this or any other appliance.
2. An LP cylinder not connected for use shall not be stored in the vicinity of this or any other appliance.

INSTALLER: Please retain these instructions with the owner so that they may maintain them for future reference.

General Safety Instructions

WARNING

Do not use the rotisserie in the rain.

WARNING

Keep any electrical supply cords and the fuel supply hose away from any heated surfaces.

WARNING

The Spare L.P. Gas Tank Barrier must be installed to prevent storage of spare L.P. Gas Tanks. Failure to comply with these instructions could result in a fire or explosion that could cause serious bodily injury, death, or property damage.

WARNING

Always have a qualified service technician perform difficult conversions or modifications.

FOR YOUR SAFETY

If you smell gas:

1. Shut off gas to the appliance.
2. Extinguish any open flames.
3. Open grill hood.
4. If odor continues, immediately call your gas supplier and local Fire Dept.

WARNING

CALIFORNIA PROPOSITION 65 -WARNING: The burning of gas cooking fuels generates some by-products which are on the list of substances that are known by the State of California to cause cancer or reproductive harm. California law requires businesses to warn customers of potential exposure to such substances. To minimize exposure to these substances, always operate this unit according to the use and care manual, provide good ventilation when cooking with gas.

WARNING

This appliance is not intended to be installed in or on recreational vehicles or boats.

WARNING

NOTE: Do Not operate the main burners and infrared back burner at the same time. This can cause warping of the roll top grill hood.

WARNING

Do not use the grill in garages, breezeways, sheds or any enclosed area. Never operate the grill in enclosed areas as this could lead to a carbon monoxide buildup, which could result in injury or death. Place the grill on a level surface. Avoid moving the grill while it is in operation.

WARNING

Never attach an unregulated gas line to the appliance. Connection to an unregulated gas line can cause excessive heat or fire.

TESTED IN ACCORDANCE WITH ANSI Z21.58b-2006/CSA 1.6b-2006 STANDARD FOR OUTDOOR COOKING GAS APPLIANCES. THIS GRILL IS FOR OUTDOOR USE ONLY.

Installation must conform with local codes, this unit should be installed in accordance with the National Fuel Gas Code No. Z223.1/NFPA 54, National Gas and Propane Installation Code, CSA B149.1 or Propane Storage and Handling Code, B149.2

FOR YOUR SAFETY

DO NOT store or use gasoline or other flammable vapors and liquids in the vicinity of this or any other appliance.

An **LP cylinder** not connected for use shall not be stored in the vicinity of this or any other appliance.

WARNING

DO NOT try lighting this appliance without reading the “**LIGHTING INSTRUCTIONS**” section of this manual.

FOR OUTDOOR USE ONLY

Grill Features

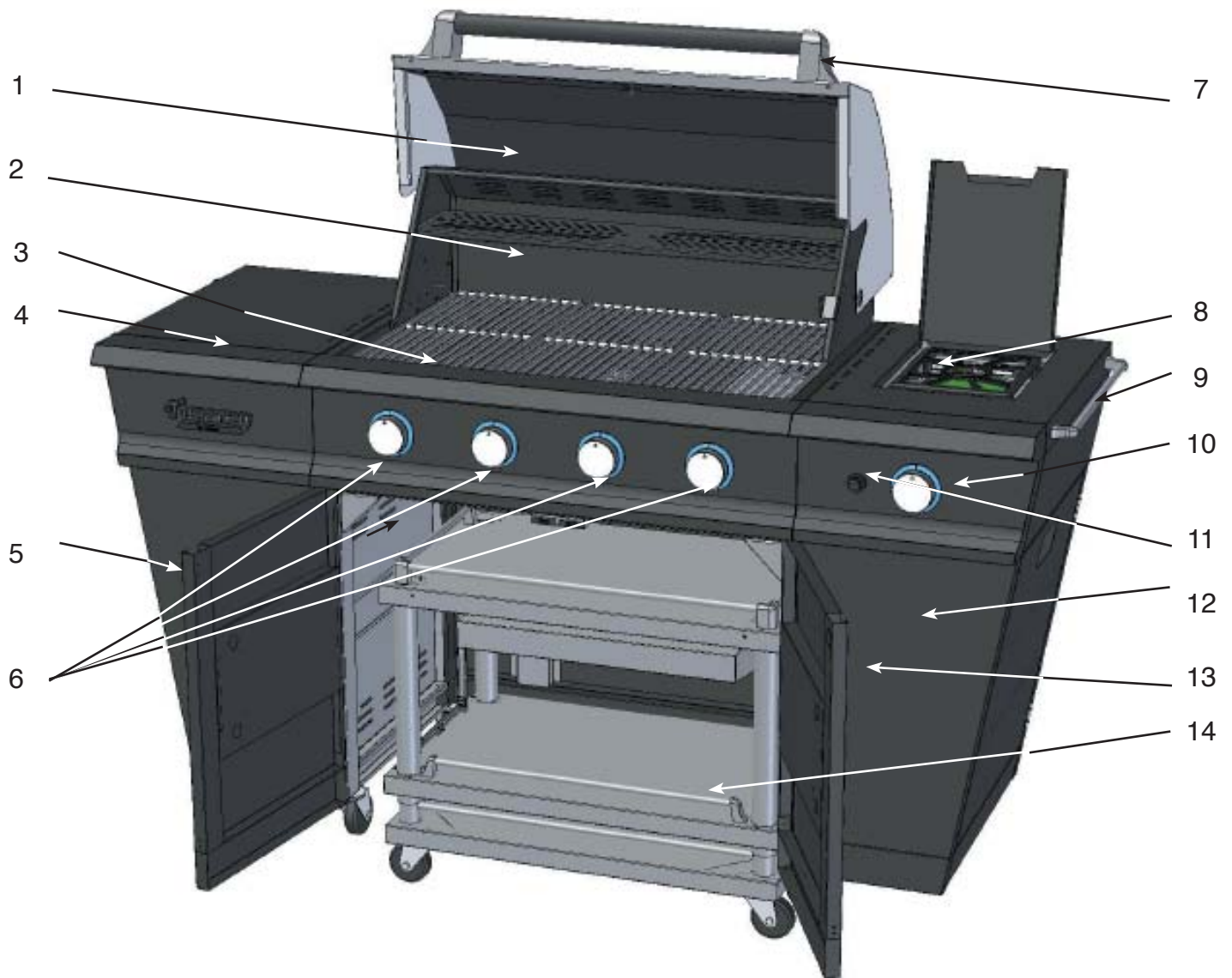

- | | |
|--------------------------------|--|
| 1. Roll top grill hood | 8. Side burner |
| 2. Bread warming rack | 9. Towel bar |
| 3. Grilling/cooking surface | 10. Control Knob: Side burner |
| 4. Side shelf | 11. Electronic igniter: main burners, side burner and bottom IR burner |
| 5. Left cart | 12. Right cart |
| 6. Control knobs: Main burners | 13. Cart doors |
| 7. Hood Handle | 14. Serving cart |

Getting Started

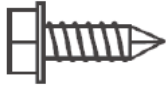

10 - Self-tapping screws

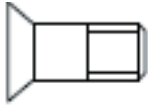

8 - Phillips sunk screws M4 x 10



26 - Phillips head screws M5 x 12

Getting Started

1. Please follow the steps in the order that they are presented.
2. Assemble the grill where you plan to use it.
3. You may want to place an old towel or cloth at the assembly site to prevent nuts and bolts from becoming lost.
4. Have a friend help. An assistant can make the assembly easier by holding the parts in place while you fasten the nuts and bolts.
5. To be ready to barbecue immediately, have the L.P. gas cylinder filled by an authorized L.P. dealer or cylinder exchange center.

Unpacking the Grill Parts

1. Remove and set aside all inner boxes and parts from the master carton.
2. Remove and set aside all wrapping paper and additional packaging from the parts.
3. Do not destroy carton or packing until your grill is completely assembled and operating to your satisfaction.

Tools needed to assemble grill:

Phillips screwdriver
Adjustable wrench
1/2" wrench or socket
1/4" nut driver or socket

TOOLS NOT INCLUDED

WARNING

Failure to follow all Danger, Warnings, and For Your Safety notices in this Grill Guide may result in serious bodily injury, death, in a fire or an explosion causing damage to property.

DANGER

Perform a Gas Leak Test explained later in this Grill Guide before operating your grill.

Grill Assembly

LEFT SHELF ASSEMBLY

1. Loosen the four M5 x 12 Phillips head screws on the middle of the grill cart left by approximately 1/4". Attach the grill cover shelf by inserting the four bolt heads into the holes on the grill cover shelf. Tighten the four screws to secure the shelf. (See Fig. 1)

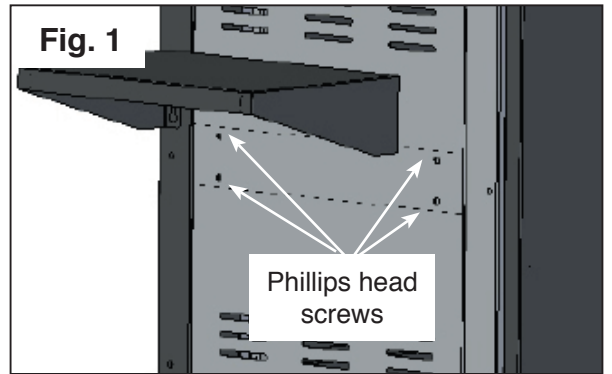

2. Use two M6 x 10 Phillips head screws to secure the towel bar to the left shelf. (See Fig. 2)

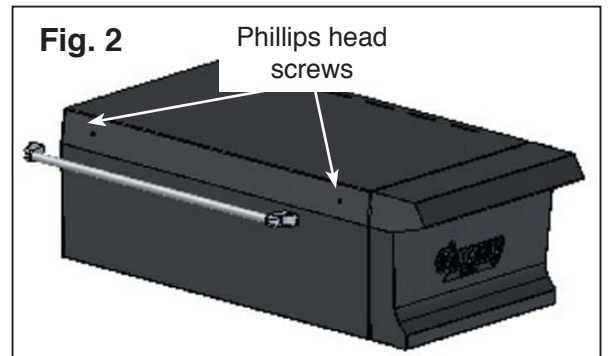

3. Use four M5 x 12 Phillips head screws and four self-tapping screws to attach the cart left. (See Fig. 3)

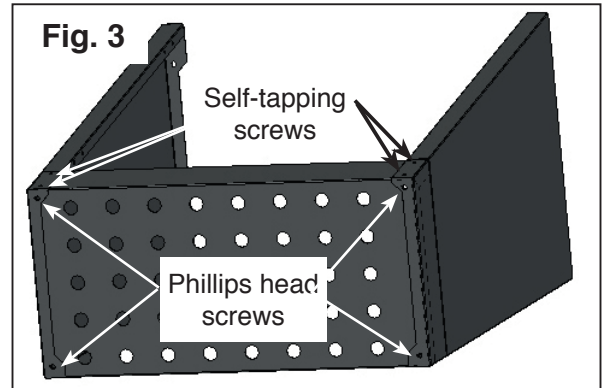

4. Attach the cart left to the left shelf with four M5 x 12 Phillips head screws. (See Fig. 4)

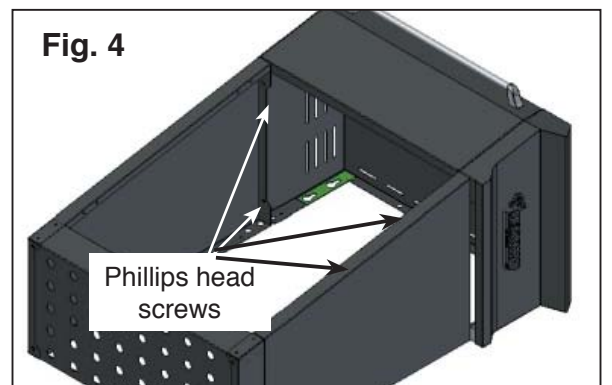

5. Loosen the bolts and slide the left cart assembly in position. Then secure the four bolts. Secure the left cart assembly to the cart assembly with seven M5 x 12 Phillips head screws. (See Fig. 5)

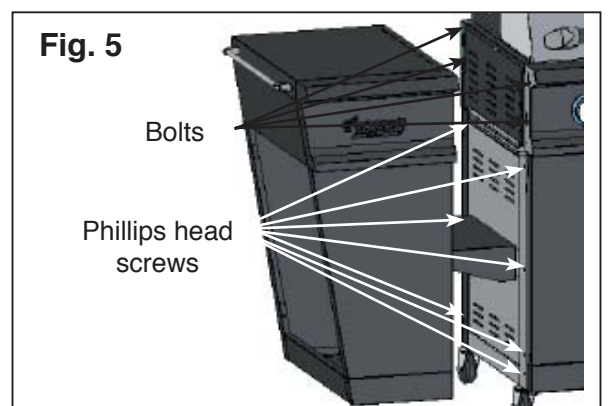

Grill Assembly

SIDE BURNER PARTS ASSEMBLY

6. Loosen the four M6 x 12 Phillips head screws on the bottom of the grill cart right by approximately 1/4". Attach the tank tray by inserting the four bolt heads into the holes on the tank tray. Tighten the four screws to secure the tank tray. (See Fig. 6)

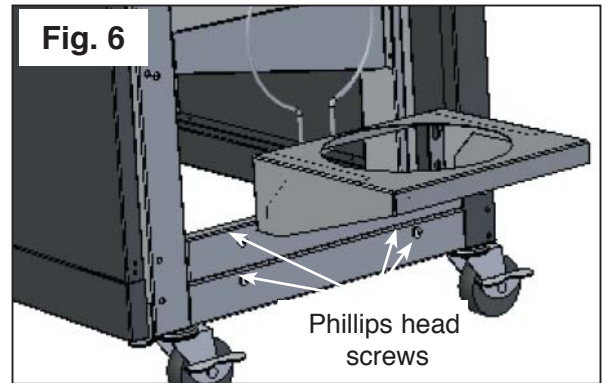

7. Use two M6 x 10 Phillips head screws to secure the towel bar to the side burner assembly. (See Fig. 7)

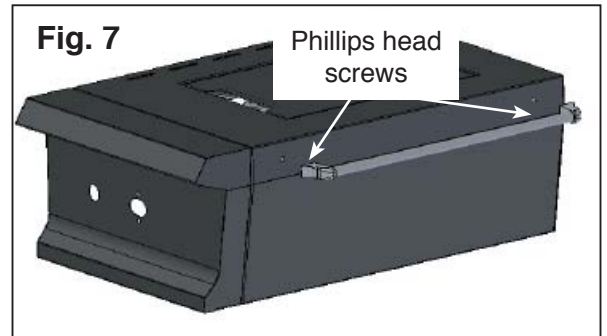

8. Use six self-tapping screws to attach the cart right. (See Fig. 8)

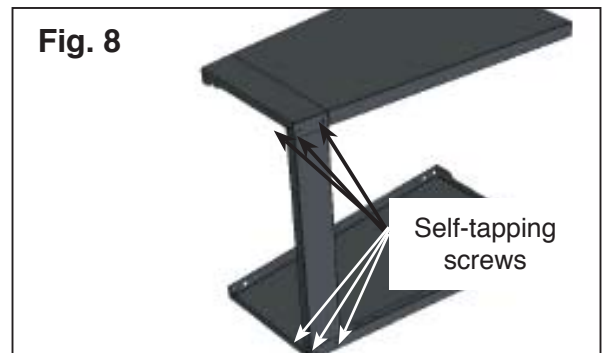

9. Attach the cart right to the side burner assembly with four M5 x 12 Phillips head screws. (See Fig. 9)

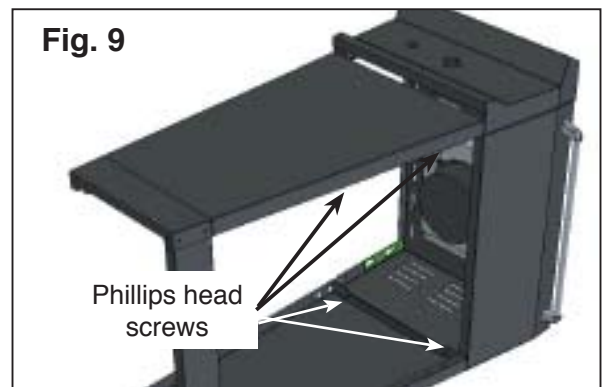

10. Loosen the bolts and slide the right cart assembly in position. Then secure the four bolts. Secure the right cart assembly to the cart assembly with seven M5 x 12 Phillips head screws. (See Fig. 10)

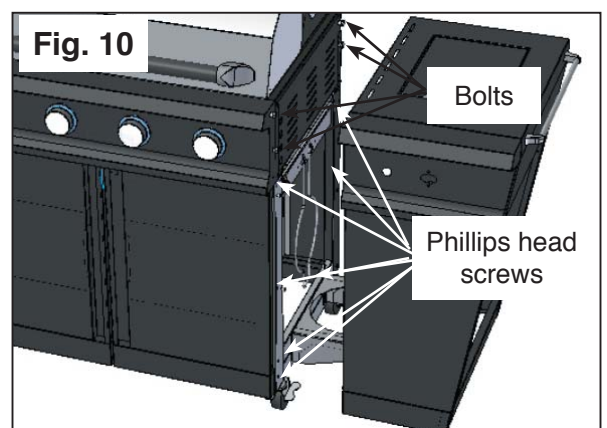

Grill Assembly

SIDE BURNER PARTS ASSEMBLY

11. Remove the two M5 x 8 Phillips head screws from the orifice bracket. Align the orifice into the center of the side burner bracket. (See Fig. 11)

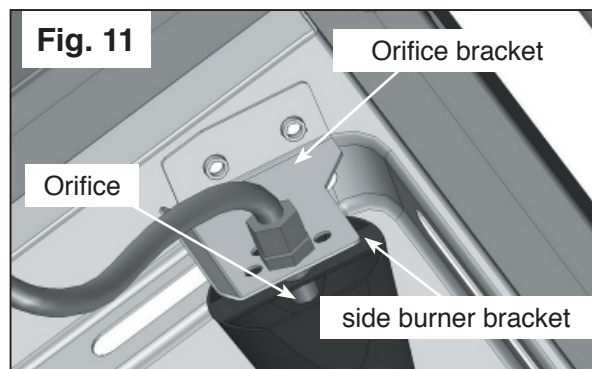

12. Use the two screws removed in step 11 to secure the orifice bracket on the side burner tray. (See Fig. 12)

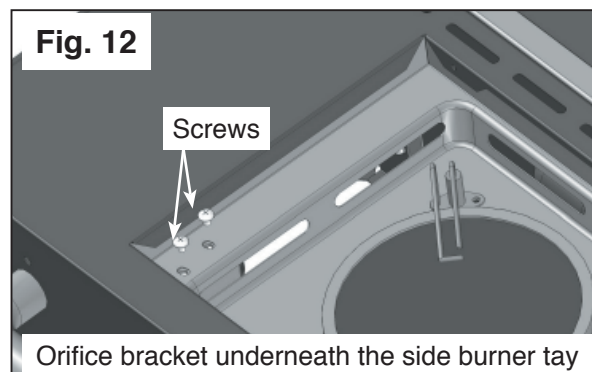

Note: Add lock washer when installing the screws in position.

13. Slide the side burner valve stem through the center hole in the front of the shelf. Insert one valve screw through the bezel and in to the side burner valve and tighten. Next, install the second valve screw through the bezel and tighten. Make sure the bezel is installed with the OFF position facing up. Install control knob, making sure to line up the flat side of the valve stem with the flat side of the knob stem. Unscrew the igniter push button from the igniter module, install the "AA" battery with positive end (-) facing out. Screw the push button back onto the igniter. (See Fig. 13)

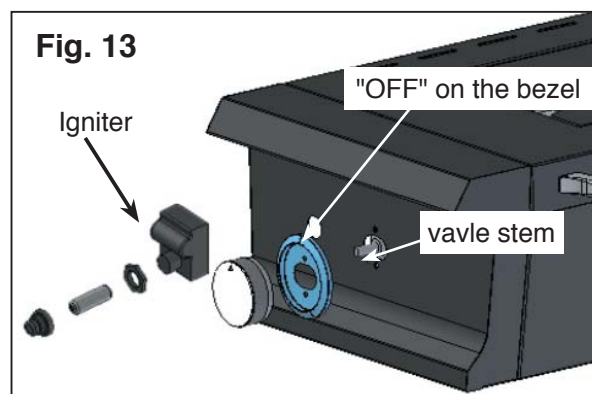

14. Attach the igniter wires to the igniter terminals. (See Fig. 14)

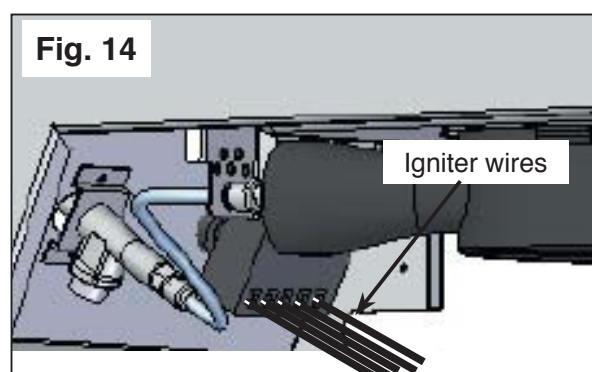

Note: It does not matter which wire goes to which terminal on the igniter module.

15. Place the side burner grate in position. (See Fig. 15)



Note: Remove all the tape before using the grill.

Grill Assembly

DOOR ASSEMBLY

16. Attach the left cart door to the left cart assembly by securing the hinges with four M4 x 10 Phillips sunk screws . (See Fig. 16)

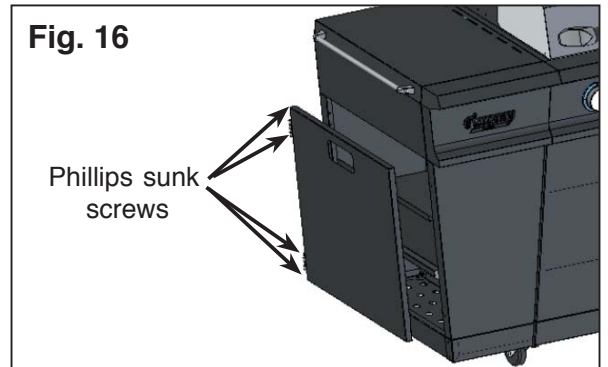

17. Attach the right cart door to the right cart assembly by securing the hinges with four M4 x 10 Phillips sunk screws. (See Fig. 17)

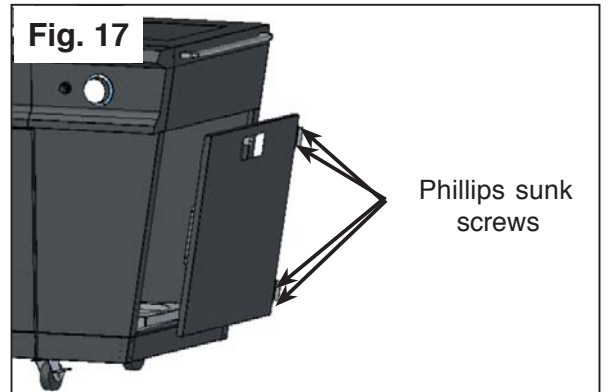

INTERIOR PARTS ASSEMBLY

18. Insert the flavor grids into the cutouts with triangle ridges facing up. Make sure the flavor grid with the long side is installed next to the bottom IR burner. Install main cooking grates on the ledges provided on the grill to create your cooking surface. Rest bread warming rack on four slots above cooking grid. (See Fig. 18)

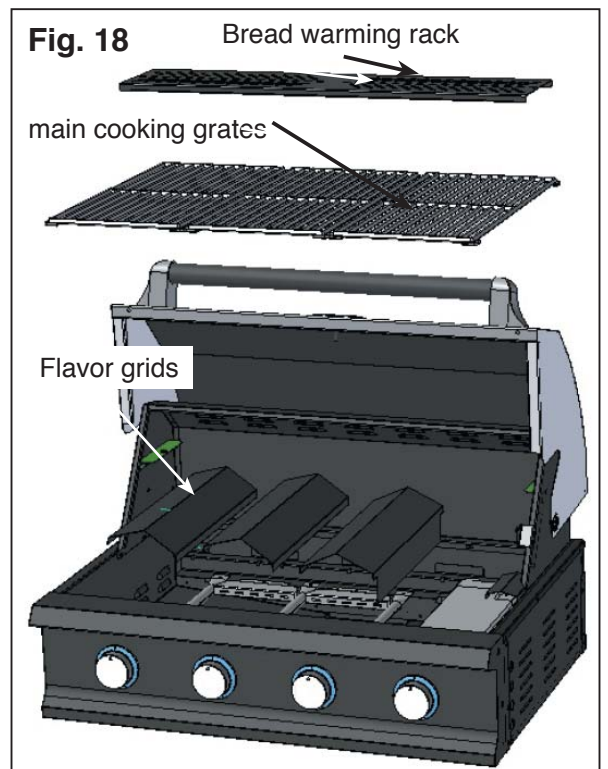

Serving Cart Usage

1. Pull the serving cart out from the grill cart.
(See Fig. 19)

Fig. 19



2. Grasp the control bars on both sides. Then lift the control bars up and the serving cart will raise and lock into position. (See Fig. 20).

Fig. 20



3. Repeat Step 2 to lower serving cart for storage back under the grill when not in use.

Gas Requirements

GENERAL INFORMATION

 **WARNING** Never attach an unregulated gas line to the appliance. Connection to an unregulated gas line can cause excessive heat or fire.

Verify the type of gas supply to be used, either Natural Gas (N.G.) or Liquid Propane (L.P.), and make sure the serial plate agrees with that of the supply. Conversion kits are available separately for an additional cost which will enable you to convert your grill from L.P. to N.G. or to convert your grill from N.G. to L.P. Please see your local dealer for more information.

 **WARNING** Always have a qualified service technician perform difficult conversions or modifications.

For natural gas installations, an installer must supply a gas shutoff valve that is easily accessible to the grill. All installer supplied parts must conform to local codes, or in the absence of local codes, with the National Electrical Code, ANSI/NFPA 70- 2002, and the National Fuel Gas Code, NFPA 54-2002/ANSI Z223.1-2002.

All pipe sealants must be an approved type and resistant to the actions of L.P. gases. Never use pipe sealant on flare fittings. All gas connections should be made by a competent qualified service technician and in accordance with local codes and ordinances. In the absence of local codes, the installation must comply with the National Fuel Gas Code, NFPA 54-2002/ANSI Z223.1-2002. Gas conversions kits may be purchased separately. When ordering gas conversion kits, have the model number, and the type of gas (N.G. or L.P.) used for your grill.

This grill and its individual shut off valve must be disconnected from the gas supply piping system during any pressure testing of that system at test pressures in excess of 1/2 PSIG (3.5 kPa.).

This grill must be isolated from the gas supply piping system by closing its individual manual shut-off valve during any pressure testing of the gas supply piping system at test pressures equal to or less than 1/2 PSIG (3.5 kPa.).

The installation of this grill must conform with local codes, or in the absence of local codes, with National Fuel Code, NFPA 54-2002/ANSI Z223.1a-2002.

Installation in Canada must be in accordance with the Standard CSA B149.1 or B149.2 (installation code for gas burning appliances and equipment) and local codes.

Gas Requirements

L.P. GAS INSTALLATION

Tuscany™ Gas Grills that are set to operate with L.P. gas come with a high capacity hose and regulator assembly. **(Note: Only use the pressure regulator and hose assembly supplied with the grill or a replacement pressure regulator and hose assemblies specified by Tuscany™).** This assembly is designed to connect directly to a standard 20 lb. L.P. cylinder. L.P. Cylinders are not included with the grill. L.P. Cylinders can be purchased separately at an independent dealer.

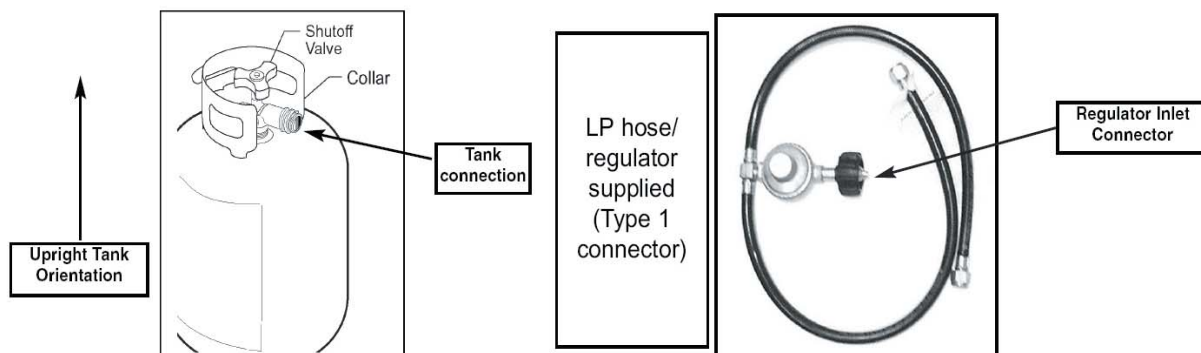

L.P. TANK INFORMATION

Never use a dented or rusted L.P. tank or cylinder with a damaged valve.

L.P. cylinders are equipped with an O.P.D (Overfilling Prevention Device). The device shuts off the flow of gas to a cylinder after 80% capacity is reached. This limits the potential for release of gas when the cylinder is heated, averting a fire or possible injury.

The L.P. cylinder must have a shut-off valve terminating in an L.P. gas supply cylinder outlet specified, as applicable, for connection No. 510 in the standard for compressed gas cylinder valve outlet and inlet connection ANSI/CGA-V-1. Cylinders must not be stored in a building, garage, or any other enclosed area. (The L.P. cylinder must have an overfill protection device, OPD, and a collar to protect the cylinder valve.)

The L.P. gas supply cylinder must be constructed and marked in accordance with the specifications for L.P. gas cylinders of the U.S. Department of Transportation (DOT) or the National Standard of Canada, CAN/CAS-B339, "Cylinders, Spheres and Tubes for the Transportation of Dangerous Goods and Commission."

L.P. TANK USE

- **When turning the L.P. tank on, make sure to open the valve SLOWLY two (2) complete turns to ensure proper gas flow. Most gas tanks now come equipped with a leak detector mechanism internal to the tank, when gas is allowed to escape rapidly it shuts off the gas supply. Opening the valve rapidly may simulate a gas leak, causing the safety device to activate, restricting gas flow causing low flames. Opening the valve slowly will ensure this safety feature is not falsely triggered.**
- When not in use, gas supply cylinder valve is to be in the "OFF" position.
- The tank supply system must be stored upright to allow for vapor withdrawal.
- The regulator and hose assembly must be inspected before each use of the grill. If there is excessive abrasion or wear or if the hose is cut, it must be replaced prior to the grill being used again.
- Cylinders must be stored outdoors out of the reach of children and must not be stored in a building, garage or any other enclosed area.
- Only a qualified gas supplier should refill the L.P. tank.
- Place dust cap on cylinder valve outlet whenever the cylinder is not in use. Only install the type of dust cap on the cylinder valve outlet that is provided with the cylinder valve. Other types of caps or plugs may result in leakage of propane.

⚠ WARNING

DO NOT store a spare L.P. gas cylinder under or near the grill. Never fill the cylinder beyond 80% full.

If this information is not followed exactly, a fire causing death or serious injury may occur.

Pre Operation Leak Testing

GENERAL INFORMATION

Although all gas connections on the grill are leak tested prior to shipment, a complete gas tightness check must be performed at the installation site due to possible shifting during shipment, installation or excessive pressure unknowingly being applied to the unit. Periodically check the whole system for leaks and immediately check the system if the smell of gas is detected.

BEFORE TESTING

1. Do not smoke while leak testing.
2. Extinguish all open flames.
3. Never leak test with an open flame.
4. Mix a solution of equal parts mild detergent or liquid soap and water.

TESTING

1. Turn off the burner control knobs.
2. Turn the top knob of the fuel supply cylinder counterclockwise (right to left) two (2) rotations to open.
3. Apply the soap solution to connections of the fuel supply assembly. If no soap bubbles appear, there is no gas leak. If bubbles form at the connections, a leak is detected. If a leak is detected, immediately turn off the gas supply, tighten any leaking fittings, turn gas on, and repeat steps 1-3.
4. Turn off the knob on the fuel supply cylinder.
5. Turn on the burner control knobs for a moment to release the pressure in the hose, then turn the control knobs back off.
6. Wash off soapy solution with cold water and towel dry.

Check all gas supply fittings before each use and each time the gas supply cylinder is connected to the regulator. Have a qualified service technician leak test the grill any time a part of the gas system is replaced.

Also it is recommended to perform a leak test at least once a year whether or not the L.P. gas supply cylinder has been disconnected.

WARNING

When leak testing this appliance, make sure to test and tighten all loose connections, including the side burner. A slight leak in the system can result in a low flame, or hazardous condition. Most L.P. gas tanks now come equipped with a leak detector mechanism internal to the tank, when gas is allowed to escape rapidly, it shuts off the gas supply. A leak may significantly reduce the gas flow making the grill difficult to light or causing low flames.

WARNING

If you cannot stop a gas leak turn off the gas supply and call your local gas or the dealer you purchased the appliance from. If necessary, replace the faulty part with the manufacturer's recommended replacement part. A slight leak could cause a fire.

Lighting the Grill

Do not attempt to "Light" the grill if the odor of gas present!!

BEFORE LIGHTING

⚠ WARNING Important! Before Lighting:

- Check the gas supply line for cuts, wear or abrasion.
- Always keep your face and body as far away from the grill as possible when lighting.

GRILL BURNER LIGHTING

Lighting the Grill with electronic igniter

1. Make sure all control knobs are in the OFF position.
2. Open the gas supply valve located on top of your L.P. tank.

ATTENTION: When turning the L.P. tank on, make sure to open the valve very **SLOWLY** two (2) complete turns to insure proper gas flow.

3. Always open the hood before attempting to light.
4. Push and turn one of the control knobs counter-clockwise to the HIGH position and immediately press the electronic igniter button. You will hear a "snapping" sound. It may be necessary to hold the electronic starter button for about 4 seconds. (See Fig. 22)

NOTE: If the burner does not light in 4 seconds, turn the knob to the OFF position and wait 5 minutes before trying again.

5. Repeat above steps to light remaining burners.

Match Lighting

If by chance the electronic igniter does not light the burner, the burner may be lit with a match attached to the match extender, located on the inside of the cart door.

Keep your face as far away from the grill surface as possible and pass the match extender through the spaces in the grill grates to the ports of the burner between the flavor grids. Position the match near the burner ports and push and turn the control knob counter-clockwise to the HIGH position.

(See Fig. 22-23)

The match extender can be stored inside the cart door by sliding the extender ring through the opening on the inside, back of the cart door. (See Fig. 24)

NOTE:

If the grill will not light after several attempts see the trouble-shooting section of this manual. Turn the control knobs to the OFF position when not in use.

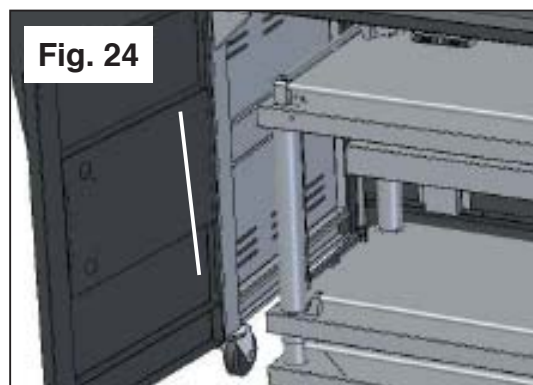
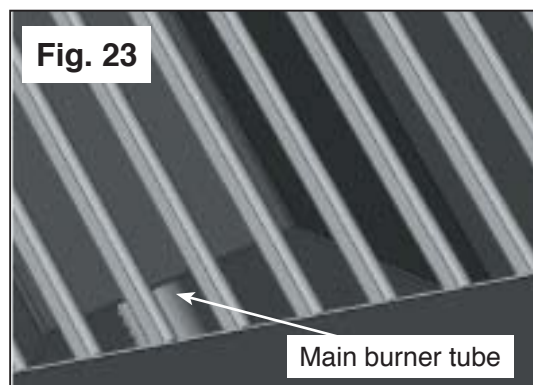
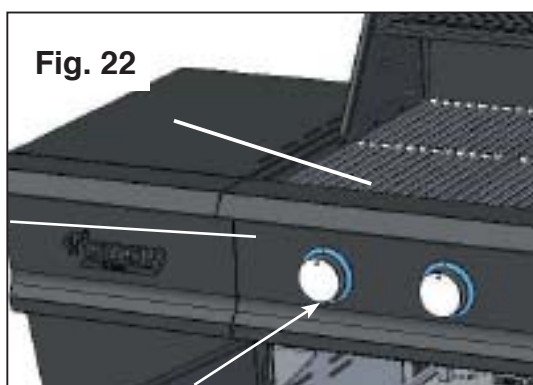
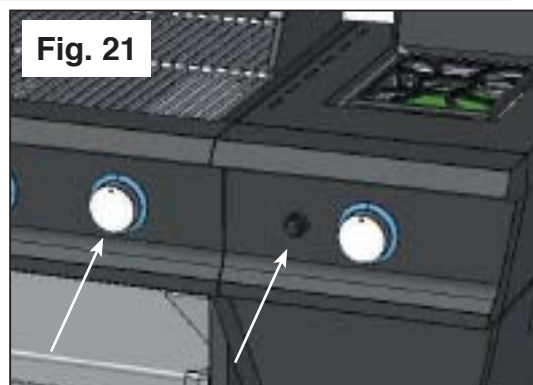

Using the Grill and Side Burner

GRILL LOCATION

⚠ WARNING Do not use the grill in garages, breezeways, sheds or any enclosed area. Never operate the grill in enclosed areas as this could lead to a carbon monoxide buildup, which could result in injury or death. Place the grill on a level surface. Avoid moving the grill while it is in operation.

NOTE: The grill will operate best if it is not facing directly into the wind.

Clearance to combustible construction - A minimum of 24" from the sides and back must be maintained from the gas grill above and below the cooking surface to adjacent vertical combustible construction.

Clearance to non-combustible construction - A minimum of 10" clearance from the back of the grill to non-combustible construction is required for the lid to fully open.

Storage of an outdoor gas cooking appliance indoor is permissible only if the cylinder is disconnected and removed from the appliance.

⚠ WARNING Heat and smoke exhaust out of the back of the grill hood opening. Make sure not to have the grill back facing your home or anything that could be damaged by heat or smoke.



GENERAL RULES

Do not leave the grill unattended while cooking!

1. Make sure the grill has been leak tested and is properly located.
2. Light the grill burners using the instructions provided in this manual.
3. Turn the control knobs to desired temperature "High, Medium, or Low" and preheat the grill for 10 minutes before cooking.
4. Adjust heat settings to meet your cooking needs for desired results.
5. Allow grill to cool down, wipe off any splatters or grease and clean the drip tray as needed.
6. Do not put a cover on the grill while it is still hot as it could start a fire.

⚠ Keep any electrical supply cords and the fuel supply away from any heated surfaces.

SIDE BURNER LIGHTING

Push and turn the control knob to the HIGH position and immediately press and hold the electronic igniter button. You'll hear a "snapping" sound. It may be necessary to hold the electronic starter button for about 4 seconds. If the burner does not light in 4 seconds, turn the knob to the OFF position and wait 5 minutes before trying again. (See Fig. 25)

MATCH LIGHTING

If by chance the electronic igniter does not light the burner, the burner may be lit with a match. Attach the match to the match extender, located inside the right cart door.

Keep your face as far away from the grill surface as possible and hold a match, attached to the match extender, near the burner ports, then push and turn the control knob counter clockwise to the HIGH position. (See Fig. 26)

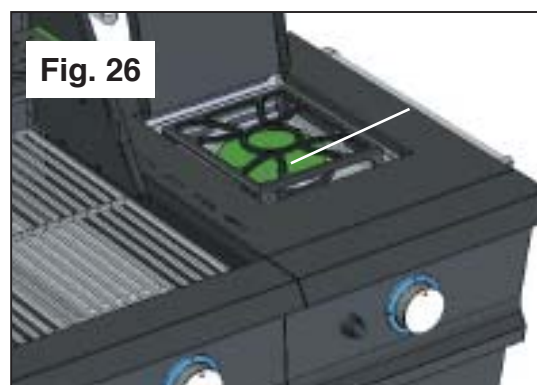
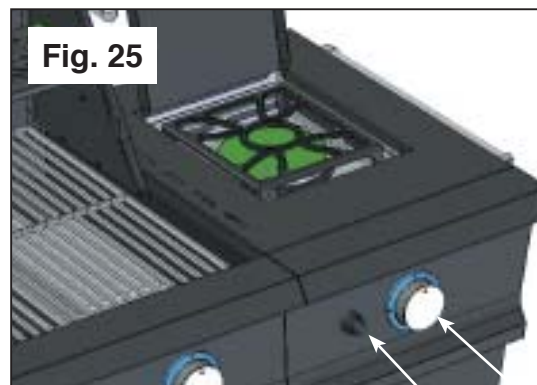

Bottom Infrared Cooking Tips

Even with an expert chef, infrared cooking can be quite a challenge. If you follow these simple suggestions, you will soon be making juicier, more savory foods than you have ever experienced before. In general, foods will cook in less time than they would take an ordinary grill. If you rotate food regularly (about every 2 minutes), extreme charring is avoided.

Infrared grills work by producing concentrated heat which quickly sears the meat. Searing holds in flavor and juices while allowing the surface to soak in smoke and food aroma that is produced as grease and drippings are vaporized by the infrared burner. The outcome is a crisp, flavorful exterior with a tender, moist interior - just the outcome you want with most grilled foods.

HOW TO GRILL WITH BOTTOM INFRARED BURNER

- Place food on grill grids and turn every 2 to 2 1/2 minutes until food is cooked to desired doneness. Do not let food cook more than 2 1/2 minutes without turning.
- Perfect cross sear marks can be made by rotating food 90°.

We recommend that you turn food being grilled on an infrared burner every two minutes during the cooking period. Never allow food to cook more than 2 1/2 minutes without turning.

Food Item

Approx. Cook Time

Chicken Breast, boneless	8-10 min.
Chicken Breast, bone-in	20-24 min.
Hamburger, 1/2 thick	5 min. Medium
	6 min. Well Done
Steak, 1" thick	6 min. Rare
	8 min. Medium
	10 min. Well Done

These are recommended times only. Due to variations in cuts of meat and personal taste, your cooking times may vary. Use your discretion when using your infrared burner.

CONTROLLING FLARE-UPS

NEVER ATTEMPT TO CONTROL A FLARE-UP DOUSING WITH WATER. BURNER DAMAGE WILL RESULT AND VOID YOUR WARRANTY.

With proper care, flare-ups should not present a problem with your grill. Minimize flare-ups by:

- Properly pre-heating the grill
- Trimming excess fat from meat
- Cleaning grill regularly to avoid grease build-up
- Repositioning meat during cooking

If flare-up occurs, move meat to a different portion of the grill until the flare-up is under control.

Care and Maintenance

PROTECTION OF INFRARED BURNERS

The burners of your grill are designed to provide a long life of satisfactory performance. However, there are steps you must take to prevent cracking of the burner's ceramic surfaces, which will cause the burners to malfunction. The following are the most common causes of cracks and the steps you must take to avoid them. **Damage caused by failure to follow these steps is not covered by your grill warranty.**

IMPACT WITH HARD OBJECTS - Never allow hard objects to strike the ceramic. You should take particular care when inserting or removing cooking grids and accessories into or from the grill. If objects such as these fall onto ceramic, it is likely to crack the ceramic.

IMPAIRED VENTILATION OF HOT AIR FROM GRILL - In order for the burners to function properly, hot air created by the burners must have a way to escape, the burners may become deprived of oxygen, causing them to backfire, especially if the burner output is set at HIGH. If this occurs repeatedly, the burners may crack. This is the reason your grill was designed with ventilation louvers. These design features give the hot air an escape route. Accordingly, never operate your grill with very little or no open space at the cooking surface (the cooking grids provide sufficient space). Also, never cover the ventilation louvers with foil or other materials that prevent air flow. Specifically, do not cover the entire surface with foil, a large pan, etc.

GENERAL MAINTENANCE

- Keep outdoor cooking gas appliance area clear and free from combustible materials, gasoline and other flammable vapors and liquids.
- Do not obstruct the flow of combustion and ventilation air.
- Keep the ventilation openings of the cylinder enclosure free and clear from debris.
- Visually check the burners

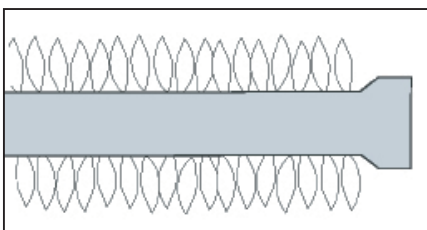

Normal: Soft blue flames

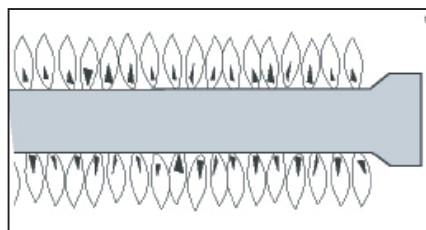

Out of Adjustment: Hard blue flames- too much air

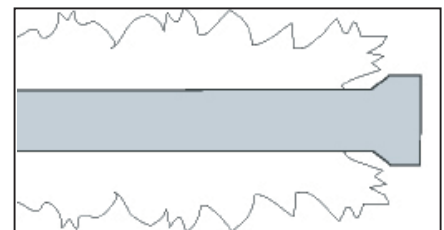

Poor Combustion: wavy, yellow flames- too little air

Care and Maintenance

DRIP TRAY

The drip tray should be cleaned periodically to prevent heavy buildup of debris.

NOTE: Allow the drip tray to cool before attempting to clean.

Important: Do not leave the grill outside during inclement weather unless it is covered. Rain water can collect inside of the grill, the grill cart or the drip tray if left uncovered. If the drip tray is not cleaned after use and the grill is left uncovered, the drip tray will fill with water causing grease and water to spill into the grill cart. We recommend cleaning and storing the drip tray after every use.

COOKING GRATES

The cooking grate can be cleaned immediately after cooking is completed and after turning off the grill. Wear a barbecue mitt and scrub the cooking grates with a damp cloth. If the grill is allowed to cool down, cleaning the grates will be easier if removed from the grill and cleaned with a mild detergent.

STAINLESS STEEL

After initial usage, areas of the grill may discolor from the intense heat given off by the burners, this is normal.

Purchase a mild stainless steel cleaner and rub in the direction of the grain of the metal. Specks of grease can gather on the surface of the stainless steel and bake on to the surface and give a worn appearance. For removal, use a non-abrasive oven cleaner in conjunction with a stainless cleaner.

NOTE: Always scrub in the direction of the grain.

IGNITER ACCESS (UNDER SIDE BURNER SHELF)

To remove igniter, unscrew igniter push button and locking nut from front panel of the side burner and igniter will fall out through the bottom.

PORCELAIN PARTS

Certain parts of your grill have a porcelain coating. Porcelain is a glass-based product, and is highly durable to standard wear and tear. However, porcelain is sensitive to concussive blows, which can create interlaced micro-fractures, or “spider-webs”. Please take care not to strike any porcelain covered parts with solid objects, drop them, or create any other concussive blows. These interlaced micro-fractures are common and may lead to minor chipping. Neither the chipping nor the interlaced micro-fractures will adversely affect the performance of your grill, and are not covered under the warranty for porcelain parts.

Troubleshooting Your Grill

GENERAL TROUBLE SHOOTING

You should inspect the burners at least once a year or immediately if any of the following conditions occur:

- The smell of gas.
- Flames appearing mostly yellow. (some yellow at the tips is OK)
- The grill will not get hot enough.
- Burners make a snapping noise.
- The grill heats unevenly.

SPIDER AND INSECT WARNING

Spider and insects can nest in the burners of this or any other grill and cause the gas to flow from the front of the burner. This is a very dangerous condition which can cause a fire to occur behind the valve panel, thereby damaging the grill and making it unsafe to operate. We recommend you check the grill and remove any spiders, insects and webs at least once a year to reduce this risk.

BEFORE CALLING CUSTOMER SERVICE

If the grill does not function properly, use the following checklist.

Problem	SOLUTION
Grill will not light when the igniter button is pushed.	<ul style="list-style-type: none">• Is your gas supply turned on?• Is there gas in your L.P. tank? Check your gas level.• Is one of your burners turned on? Allow up to four seconds of gas flow to ignite.• Is your igniter working? You should hear a snapping sound when you press the igniter? If you hear a snapping sound can you see a spark at the electrodes? Note - You will need to remove your cooking grates and flavor grids to see the electrodes.• Check to see if your igniter battery is installed correctly with the positive side to the outside.• Check your igniter battery and replace if needed.• Check for loose wire connections to the igniter or electrodes.• Check to see if debris is blocking the electrodes.• If the igniter is not working can you light the grill with a match?

Troubleshooting Your Grill

Problem

Grill will not light with a match or low heat with dial set to "High" position.

SOLUTION

- Is your gas supply fully turned on?
- Is there gas in your L.P. tank? Check your gas level.
- Shut off gas supply, disconnect gas line at tank, reconnect the line to the tank.
- Make sure all the knobs are in the "OFF" position, then open the gas supply valve on the L.P. tank very slowly 1/4 turn, then open fully (at least two full turns). Check Flame.
- Check to insure the gas supply line or hose is not kinked.
- If only one burner appears low, check and clean the burner ports if clogged or dirty.
- Check for leaks.

Note: PreHeating time can take from 5 to 10 minutes.

Flame is erratic

- Check gas connection
- look for kinked hose.
- make sure gas supply valve is fully open.
- Gas level may be low.
- Grill may be in need of cleaning.

Flareups

- Check flavor grids and cooking grates for excess food or grease buildup.
 - Ensure grill is not placed directly in the path of wind.
 - Be sure drip tray is clean, (do not use aluminum foil on drip tray.)
- Note: Some flareups may be inevitable if cooking greasy foods.**

Burner flame is mostly yellow or orange, possibly in conjunction with smell of gas.

- Check the burner inlet for obstructions. Particularly at air inlets for each burner.
- Grill may be in an area that is too windy.

Replacement Parts List

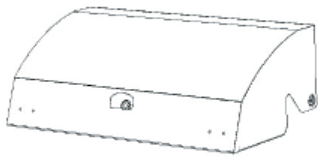

Hood Assembly
SASBA00173C
1 set

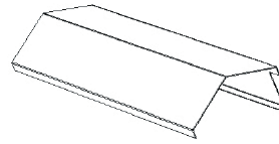

Flavor Grid B
SBNMC00139A
1 piece



Hood Handle Assy.
SASQG00005A
1 set

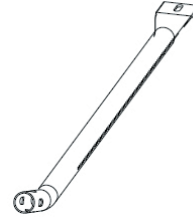

Main Burner Tube
RCOAZ00071A
1 piece



Temperature Gauge
RCOZZ00029A
1 piece



Front Face Assy.
SWLBA00344A
1 set



Bread Warming Rack
SBNMC00090A
1 piece



Manifold & Valve Assembly
RCOZZ00530A
1 set

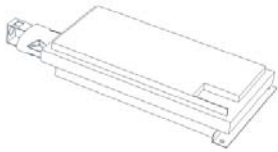

Bottom IR Burner Assembly
RCOZZ00208A
1 set

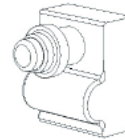

Igniter
RCOZZ00027A
1 piece



Bottom IR Igniter
RCOZZ00112A
1 piece

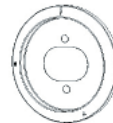

Bezel
RCOAG00003A
1 piece

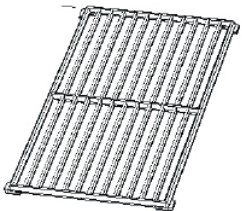

Main Cooking Grate
RCOLC00006A
1 piece



Knob
RCOFE00001A
1 piece



Flavor Grid A
RCOMC00005A
1 piece

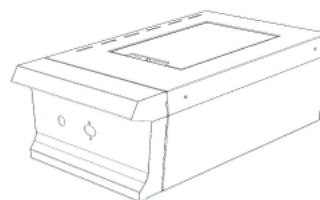

Side Burner Assembly
SASCB00557B
1 piece

Replacement Parts List



Side IR Burner
RCOZZ00207A
1 piece



Orifice Bracket
SBNAB00062A
1 piece

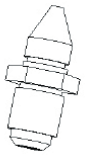

Side Burner Orifice
RCODZ00045A
1 piece

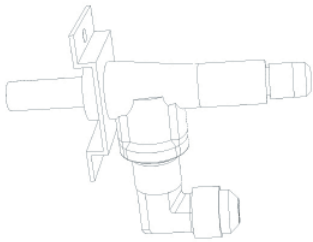

Side Burner Valve Assembly
RCOPZ00001A
1 set



Side Burner Grate
RCOLC00007A
1 piece



Right Cart Front
SASCD00588A
1 set

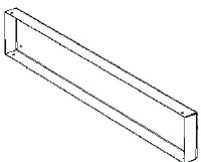

Right Cart Base Bar
SBNCD00561A
1 set



Right Cart Back
SBNCD00560A
1 set



Right Cart Door
SBNCB00550B
1 set

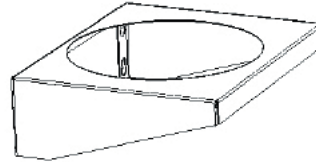

Tank Tray
SBNCD00563A
1 set

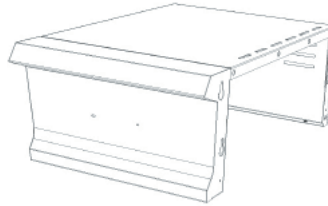

Side Shelf Assembly
SASCB00547B
1 set



Towel Bar
SCTQG00013A
1 set



Left Cart Front
SASCD00548A
1 set

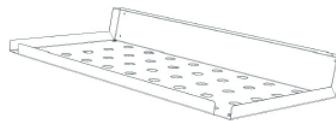

Left Cart Base
SBNCD00554A
1 set



Left Cart Back
SBNCD00552A
1 set



Left Cart Door
SBNCD00550A
1 set

Replacement Parts List



Grill Cover Shelf
 SBNCD00555A
 1 set



Tank Barrier Shelf
 SBNCD00585A
 1 set

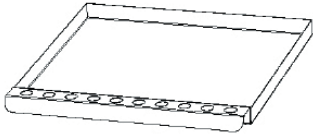

Drip Pan
 SBNMC00398A
 1 set



Swivel Caster with Lock
 RCOZZ00218A
 1 piece

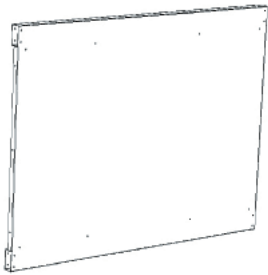

Cart Back
 SBNCB00595A
 1 set



Swivel Caster
 RCOZZ00219A
 1 piece



Cart Door Right
 SBNCD00567A
 1 set

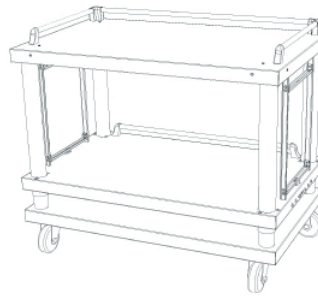

Serving Cart
 SWLCD00586A
 1 set



Cart Door Left
 SBNCD00571A
 1 set



Cart Side Left
 SWLCD00573A
 1 set

Not Shown:

RCOZZ00213A	Main Igniter w/ Wire 540
RCOZZ00214A	Main Igniter w/ Wire 740
RCOZZ00215A	Main Igniter w/ Wire 920
RCOZZ00216A	Bottom IR Igniter Wire 700
RCOZZ00090A	Side Burner Igniter Wire 300
RCOOE00002A	"TUSCANY" Logo

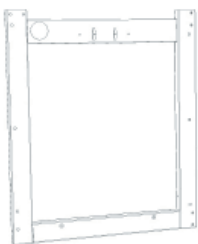

Cart Side Right
 SWLCD00573B
 1 set



Tank Ring
 RCOCD00001A
 1 piece

LIMITED WARRANTY

Sure Heat Mfg warrants that for 2 years from the date of purchase, the stainless steel panels will not break due to defects in material or workmanship. All other components of this grill are warranted free from defects in material and workmanship for one year from the date of purchase. Sure Heat Mfg. at its option, will repair or replace this product or any component of the product found to be defective during the warranty period. Replacement will be made with a new manufactured product or component. If the product is no longer available, replacement may be made with a similar product of equal value. This warranty does not include transportation or shipping costs of any kind. This is your exclusive warranty.

This warranty is valid for the original retail purchaser from the date of initial retail purchase and is not transferable. Keep the original sales receipt. Proof of purchase is required to obtain warranty parts.

This warranty does not cover normal wear of parts such as scratches and dents of the stainless steel components or damage resulting from any of the following:

- negligent use or misuse of the product, including exposing the product to chemicals or cleaning products not approved by Sure Heat Mfg.
- corrosion, rust or discolouring of any kind.
- use or installation contrary to specified instructions and applicable building codes, including heating the product to temperatures above its rated specifications which can cause considerable warping
- disassembly, including removal of the product from a built-in installation
- damage resulting from accident, alteration, misuse, abuse, hostile environments, or improper installation
- repair or alteration
- acts of God, such as fire, flood hurricanes, and tornadoes
- gas cylinders, propane tanks or other fuel delivery systems, including connections to a household fuel supply
- usage other than single-family household use such as commercial or industrial use
- minor warping or discolouration of parts, which is normal and not a defect under this warranty

DO NOT RETURN THIS PRODUCT TO THE PLACE OF PURCHASE

If the Grill does not operate properly, first thoroughly carry out the instructions provided with the unit to ensure that the appliance is installed correctly and check the trouble shooting section in the use and care manual.

We recommend you return the warranty registration card so that you can be contacted with any questions of safety arise that could affect you. The return of the warranty registration card is not a condition for warranty coverage.

Because of continuing product improvement these specifications are subject to change without notice.

if you have other questions or need replacement parts contact our
Customer Service Hotline at (800) 229-5647 or
visit our website at www.sureheat.com

Sure Heat Manufacturing 1861 West Oak Parkway Marietta, GA 30062