

Tools needed for assembly:  
1 - Adjustable Wrench

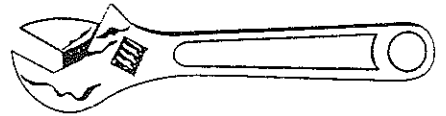

## Use and Care Manual

## Model Numbers

EGS26L-SSP  
EGS26N-SSP

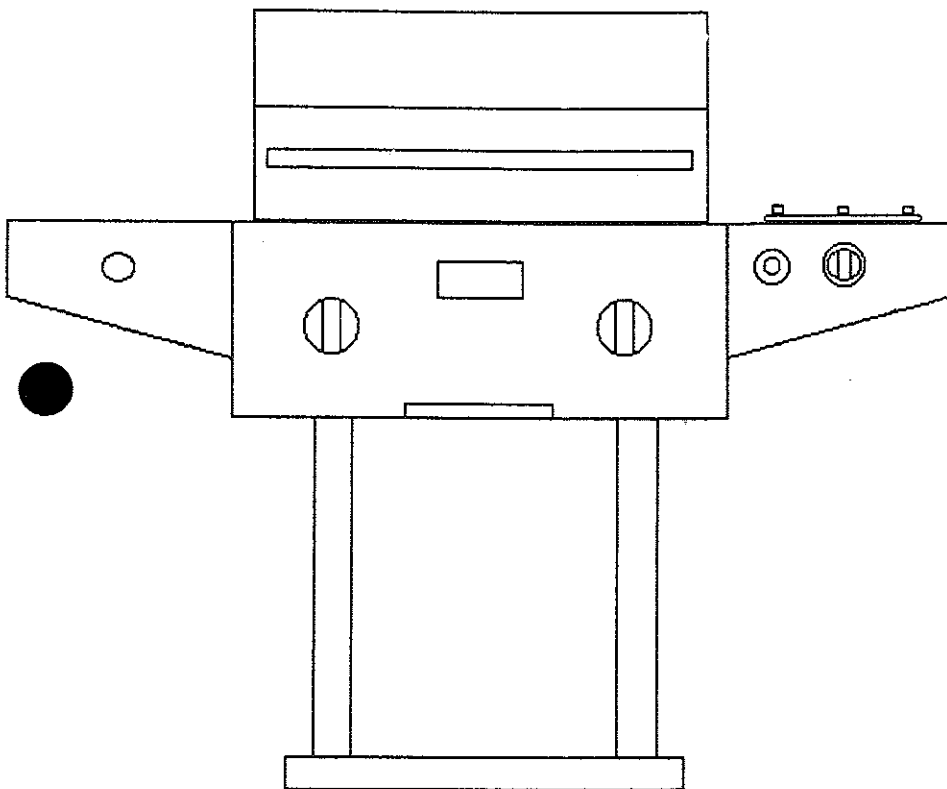

SureHeat Manufacturing  
3130 Moon Station Road  
Kennesaw, GA 30144  
Tel: (770) 422-8008  
Fax: (770) 424-3842

### FOR YOUR SAFETY

If you smell gas :

1. Shut off gas to the appliance.
2. Extinguish any open flames.
3. Open lid.
4. If odor continues, immediately call your gas supplier

### FOR YOUR SAFETY

Do Not store or use gasoline or other flammable vapors and liquids in the vicinity of this or any other appliance.

### WARNING

Do Not try lighting this appliance without reading the "LIGHTING INSTRUCTIONS" section of this manual.

**TESTED IN ACCORDANCE WITH ANSI Z21.58a-1993 STANDARD FOR OUTDOOR COOKING GAS APPLIANCES. THIS GRILL IS FOR OUTDOOR USE ONLY.**

Check your local building codes for the proper method of installation. In the absence of local codes, this unit should be installed in accordance with the National Fuel Gas Code No. Z223.1-1998 and the National Electrical Code ANSI NFPA No. 70-1990

**Made In USA**

**For Outdoor Use Only**

**This appliance is not intended to be installed in or on recreational vehicles or boats.**

■ **PLEASE RETAIN THIS MANUAL FOR FUTURE REFERENCE**

**CALIFORNIA PROPOSITION 65 - WARNING**  
The Burning of gas cooking fuel generates some byproducts which are on the list of substances which are known by the State of California to cause cancer or reproductive harm. California law requires businesses to warn customers of potential exposure to such substances. To minimize exposure to these substances, always operate this unit according to the use and care manual, ensuring you provide good ventilation when cooking with gas.

## **Statement Of Commitment**

---

Congratulations and thank you for your purchase of the EMBERGLOW Gas Grill. Your grill has been designed to provide the very best in outdoor cooking enjoyment. We believe it is the finest grill on the market. For your safety please read all the assembly instructions and care and use directions before operating the appliance.

## **IMPORTANT SAFETY INFORMATION**

---

- Read this manual carefully before using your grill to reduce the risk of fire, burn hazard or other injury.
- Extreme care should be used because of the high temperatures produced by this appliance. **CHILDREN SHOULD NOT BE LEFT UNATTENDED IN AN AREA WHERE THE GRILL IS BEING OPERATED.**
- This appliance must be kept clear from combustible materials, gasoline or other flammable vapors and liquids. Do not allow flammable materials to come in contact with grate, burner or hot surfaces.
- Do not repair or replace any part of this appliance unless it is specifically recommended in this manual. All other service should be conducted by a qualified service technician.
- Follow the installation and servicing instructions provided with this product. Have your grill installed by a qualified service technician. Locate the main gas supply valve so that you know how to shut the gas off to your grill. If you smell gas, make sure all gas connections are tight before operation. If you continue to smell gas call a qualified technician.
- When lighting a burner, always pay close attention to what you are doing. Be certain you are pushing the ignitor that lights the burner you intend on using.

## Shelf and Side Burner Assembly

Attach Side Burner Shelf to the right side of the grill body. Simply insert all 4 shelf hooks into the appropriate slots on the grill and push down into place (See Fig. 1). The "Drawer Shelf" should be installed to the left side of the grill the same way.

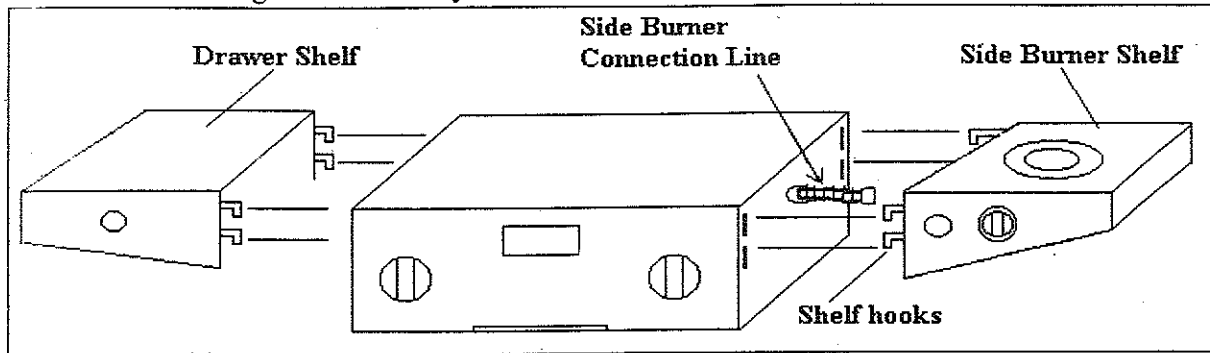

Fig. 1 Attach Side Burner Shelf and Drawer Shelf to the appropriate side of the grill body by inserting shelf hooks into the side of the grill and pushing down on the shelf assembly.

Attach Side Burner Connection Line to the side burner valve from the under side of the right Side Burner Shelf (See Fig. 2). Place side burner grate over side burner as shown below.  
Note: Secure the connection tightly with a wrench.

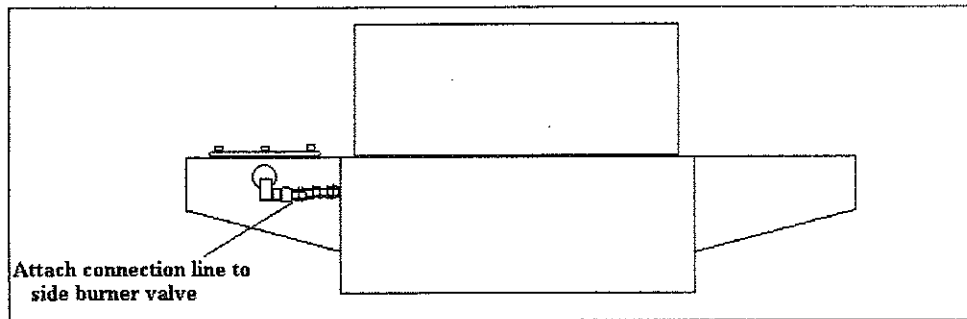

Fig. 2 Attach connection line to side burner valve as shown above. (Back View of the Grill)

## Ignitor Assembly

Place ignitor through the hole on the Side Burner Shelf and secure it with the ignitor nut. Attach the ignitor wires as shown in Fig. 3. Place the battery into the ignitor (positive side first) and screw the button down to the shelf. Attach Side Burner and Main Burner ignitor wires to the ignition terminal as shown below.

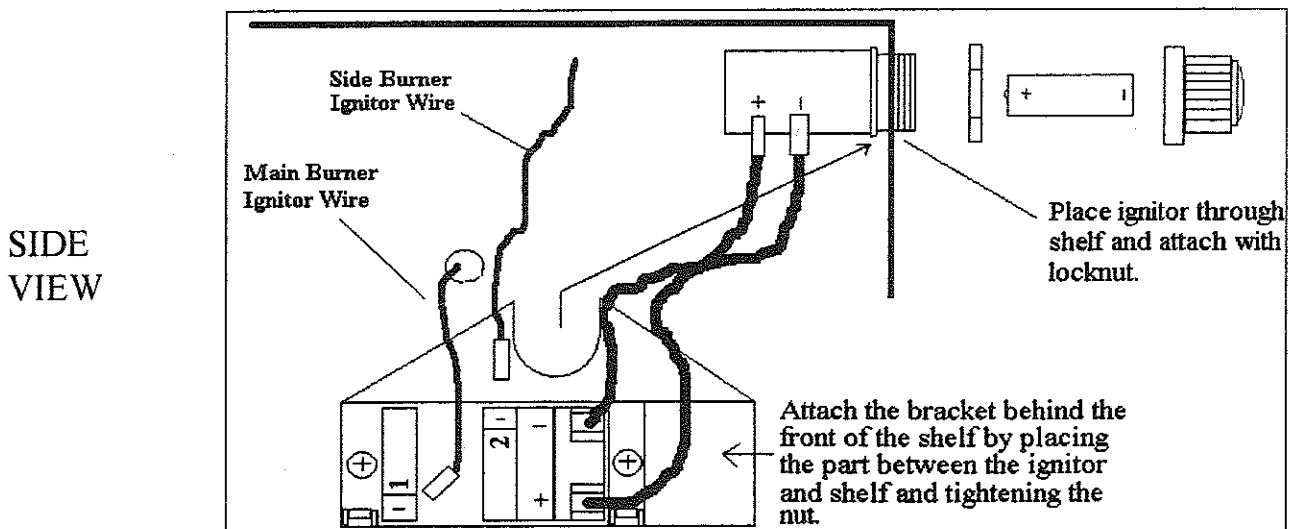

Fig. 3 Attach ignitor to Right Burner shelf as shown above.

## Pedestal and Base Assembly

Attach both the Pedestal and the Wheel Channels to the Base with the 4 bolts provided with the unit (See Fig. 4). Align the holes in the bottom of the Pedestal, the Base and the Wheel Channels and insert the bolts that are provided.

**Note:** Securely tighten the bolts with a wrench.

Place the Grill Body on top of the Pedestal Assembly and loosen the four bolts in the bottom of the grill. Align the bolts on the bottom of the grill with the holes in the top of the Pedestal (See Fig. 4). Be sure to tighten the 4 bolts with a wrench.

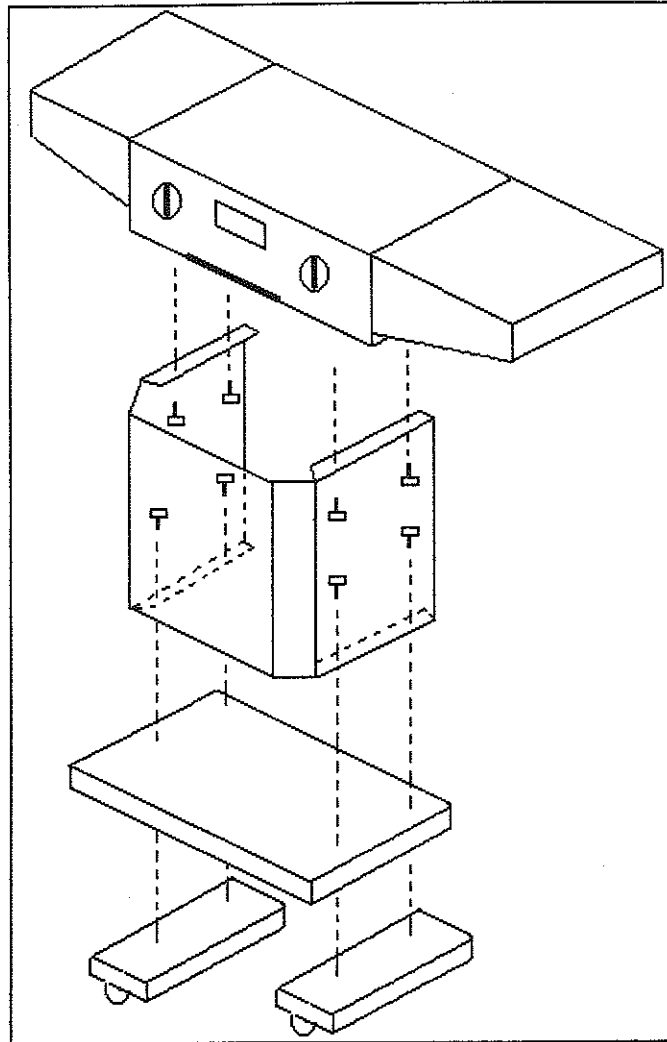

Fig. 4 Main Grill Body Assembly

## Gas Hook-Up Instructions

Verify the type of gas supply to be used, either Natural or L.P., and make sure the marking plate (located on the back of the unit) agrees with that of the supply.

**Never attach an unregulated gas line to the appliance.**

For Natural Gas Installations, an installer must supply a gas shutoff valve that is easily accessible to the grill. All installer supplied parts must conform to local codes, or in the absence of local codes, with the National Electrical Code, ANSI/NFPA 70-1990, and the National Fuel Gas Code, ANSI Z223.1-1998.

All pipe sealants must be an approved type and resistant to the actions of L.P. gases.

## Gas Hook-Up Instructions

The appliance and its individual shut-off valve must be disconnected from the gas supply piping system during any pressure testing of that system at test pressures in excess of ½ PSIG (3.5 kPa).

The appliance must be isolated from the gas supply piping system by closing its individual manual shut-off valve during any pressure testing of the gas supply piping system at test pressures equal to or less than ½ PSIG (3.5 kPa).

The installation of this appliance must conform with local codes or, in the absence of local codes, with National Fuel Code, ANSI Z223.1a-1998.

Installation in Canada must be in accordance with the Standard Can1-b149.1 and/or .2 (installation code for gas burning appliances and equipment) and local codes.

## L.P. Gas Installations

Sure Heat Gas Grills that are set to operate with L.P. gas come equipped with a high capacity hose and regulator assembly. This assembly is designed to connect directly to a standard 20 lb L.P. cylinder (18-1/4" high, 12-1/4" diameter).

Connect the female end of the regulator assembly hose to the flare fitting located at the bottom backside of the grill. Make sure all connections are tight. (When the burners are in operation, the manifold pressure should be 11" w.c.)

## L.P. Tank Information

Never use a dented or rusted L.P. tank or cylinder with a damaged valve.

The cylinder must be provided with a shut-off valve terminating in an L.P. gas supply cylinder outlet specified, as applicable, for connection No. 510 in the standard for compressed gas cylinder valve outlet and inlet connection ANSI/CGA-V-1. Cylinders must not be stored in a building, garage or any other enclosed area.

L.P. Gas supply cylinder to be used must be constructed and marked in accordance with the specifications for L.P. gas cylinders of the U.S. Department of Transportation (DOT) or the National Standard of Canada, CAN/CSA-B339, "Cylinders, Spheres and Tubes for the Transportation of Dangerous Goods."

## Natural Gas Installation

The gas inlet supply pressure should be between 5" and 14" w.c. A step down regulator is required if the line pressure is in excess of 14" w.c.

Check your local gas utility company or with local codes for instructions on installing gas supply lines. Be sure to check on type and size of run, and how deep to bury the line. If the gas supply line is too small, the grill will not operate correctly.

Any joint sealant used must be an approved type and be resistant to the actions of L.P. gases.

Attach the natural gas regulator (supplied with your grill) to the brass fitting coming out the bottom, backside of the grill (be sure the arrow on the regulator is pointing up towards the grill). Attach your gas line to the 3/8" flare fitting coming out of the natural gas regulator at the back of the grill.

Place the installer supplied shut-off valve in an accessible location to enable the gas supply to be cut off to the unit.

## Grill Location

Do not use in garages, breezeways, sheds or any enclosed area. Never operate the grill in enclosed areas as this could lead to a carbon monoxide buildup, which could result in injury or death. Place the grill on a level surface. The grill will operate best if it is not facing directly into the wind. Avoid moving the grill while it is in operation.

Clearance to combustible construction- A minimum of 12" from the sides and back must be maintained from the gas grill above and below the cooking surface to adjacent vertical combustible construction.

Clearance to non-combustible construction- A minimum of 3" clearance from the back of the grill to non-combustible construction is required for the lid to fully open.

## Leak Testing

1. Mix solution of equal parts mild detergent or liquid soap and water.
2. Turn off the burner control knobs.
3. Turn the top knob of the fuel supply cylinder counterclockwise (right to left) one rotation to open.
4. Apply the soap solution to connections of the fuel supply assembly and the side burner assembly. If no soap bubbles appear, the grill is okay for use. If bubbles form at the connections, a leak is detected.
5. Turn off the knob on the fuel supply cylinder.
6. Turn on the burner control knobs for a moment to release the pressure in the hose, then turn the control knobs back to off.
7. Wash off soapy solution with cold water and towel dry.

In case of leak; often tightening the joint will stop a leak. If necessary, replace the faulty part with a replacement part recommended by the manufacturer.

Perform a leak test each time the gas supply cylinder is connected to the regulator. Leak test any time a part of the gas system is replaced. Perform a leak test at least once each year whether the L.P. gas supply cylinder has been disconnected or not.

## Component Assembly

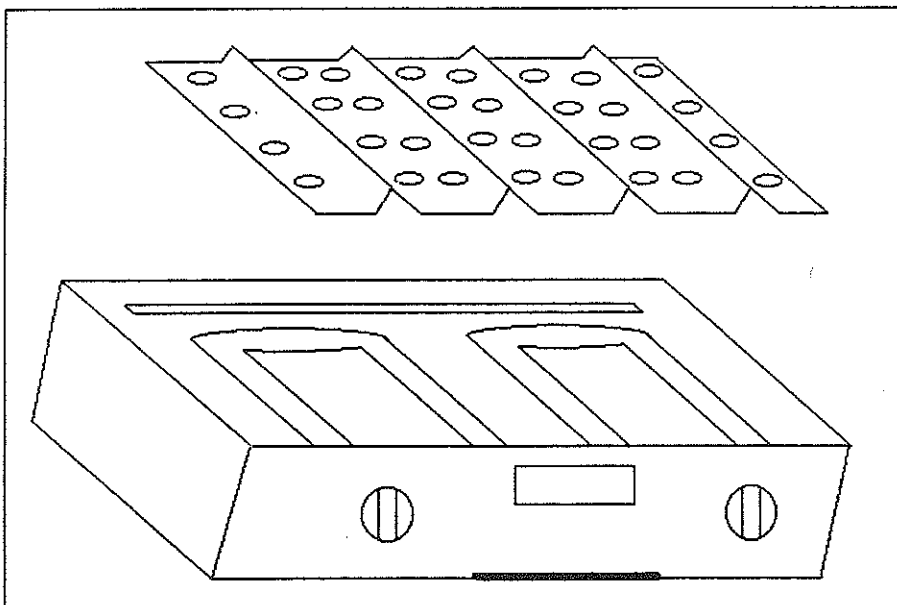

Grill Components- Each grill consists of the main burners, the flavorizer, and the main and side burner grates. The burners are ported in a way to achieve maximum efficiency. The flavorizer is placed over the burners to evenly disperse the heat over the cooking area. The cooking grates are then placed on the ledges provided on the grill to create your cooking surface.

Fig. 5 The flavorizer Grate should be positioned over the burner system.

# Using The Grill

**Do Not leave the grill unattended while cooking!**

1. Make sure the grill has been leak tested and is properly located.
2. Light the grill burners using the instructions on this page.
3. Turn the control knobs to "High" and preheat the grill for 10 minutes.
4. Place the food on the grill and cook. Adjust heat setting between "High" and "Low" if necessary.

## Lighting The Grill

**Warning: Important! Before lighting....**

Check the gas supply line for cuts, wear or abrasion.

If the unit is set to operate on L.P. gas, screw the regulator into the tank. Leak check the hose and regulator connections with soap and water solution before operating the grill.

## Grill Lighting Instructions

Turn all knobs to "off" then turn the gas supply on. Always keep your face and body as far away from the grill as possible when lighting.

**Do not attempt to "Light" if the odor of gas is present.**

Open the lid, push and turn one of the control knobs to the "High" position and immediately press the electronic starter button. You'll hear a snapping sound. At the same time a spark will be provided at the main and side burner of the

grill. It may be necessary to hold the electronic starter button for about 4 seconds. If the burner does not light in 4 seconds, turn knobs to "Off" and wait 5 minutes before trying again. If the burner will not light after several attempts then the burner can be match lit.

Keep your face as far away from the grill as possible and pass a lit, long stem match through the spaces in the grill rack to the ports of the burner you are trying to light. If attempting to light the right burner, ensure that only that burner control knob is used. Position the match near the burner ports. Push and turn the control knob to the "High" position. If the burner does not light in 4 seconds turn the knob off, wait 5 minutes and try again. If the burner will not light after several attempts see the Troubleshooting section on page 8 of this manual.

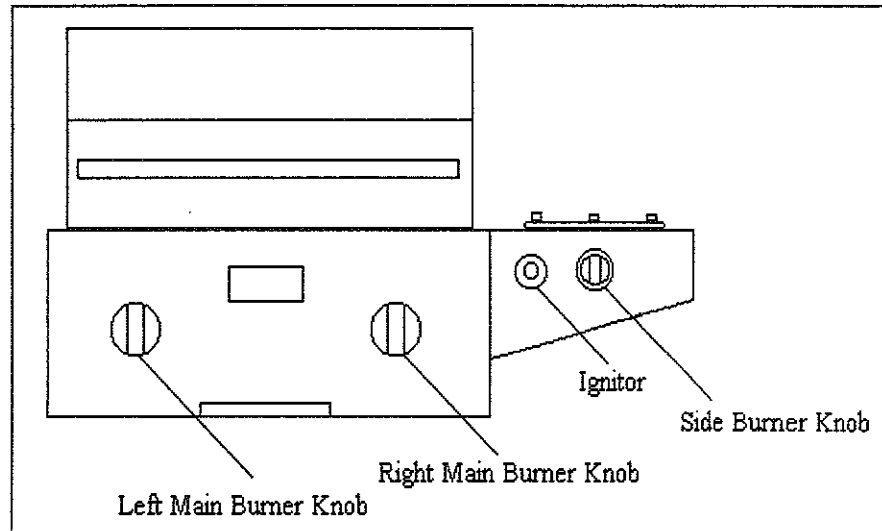

**Fig. 6 Knob and electronic starter location.**

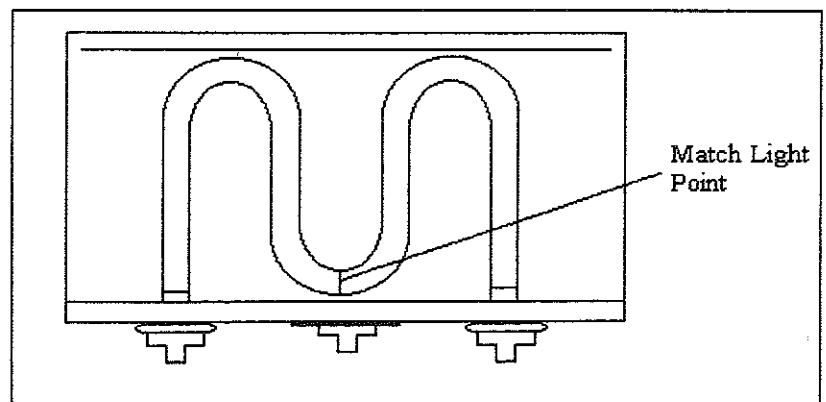

**Fig. 7 Match light location.**

# Care and Maintenance

## Cleaning

The drip tray located at the bottom of the grill should be cleaned periodically to prevent heavy build up of debris. The drip tray may be lined with foil for easier cleaning.

The cooking grates can be cleaned immediately after cooking is completed. Wear a barbecue mitt and scrub the cooking grates with a damp brass bristle barbecue brush. If the grill is allowed to cool down cleaning will be more difficult.

The grill is made from a non-rusting stainless steel. Purchase a mild stainless steel cleaner and scrub in the direction of the grain in the metal. To remove baked in grease an abrasive pad may be needed.

**Note: Be sure to scrub in the direction of the grain.**

## Troubleshooting

Problem	What To Do
Grill will not light when the ignitor button is pushed	Remove the cooking grates. Watch the tip of the electrode. You should see a spark when the ignition button is depressed. <ul style="list-style-type: none"><li>• If there is no spark, check for loose wire connections.</li><li>• Check to see if debris is blocking the electrode sparks.</li><li>• Check battery/replace battery</li></ul>
Low heat with knob in "High" position.	<ul style="list-style-type: none"><li>• Is the supply line bent or kinked?</li><li>• Is the gas supply or gas pressure low?</li><li>• Is the L.P. tank empty?</li></ul>

## LIMITED WARRANTY

Emberglow Grills have a 5 Year Warranty on all stainless steel parts, 3 year Warranty on the burners and a one year warranty on all other parts and labor.

**IMPORTANT:** For warranty registration, you must fill out and return the warranty registration card supplied with the grill. Service calls cannot be addressed without your information on file.

### SERVICE AND LIMITED WARRANTY

If the Emberglow Grill does not operate properly, first thoroughly carry out the instructions provided in Troubleshooting, and ensure that the appliance is installed correctly.

If the problem persists and you feel you require service, contact your dealer for the nearest authorized agency to perform service. Only authorized agencies can perform warranty service. Sure Heat Manufacturing will not pay for service calls to:

- Correct the installation.
- Instruct you how to use the equipment.
- Repairs when the appliance is used on other than normal home use.
- Damage resulting from accident, alteration, misuse, abuse, hostile environments, improper installation or installation not in accordance with local codes.

If you have other questions, please contact Customer Service Hotline  
(800) 229-5647